



PRODUCTS

- DUMPBODY
- SPREADER
- CHIPPER BODY
- GRAPPLE & HURRICANE
- ROLL-OFF
- TRAILER & PUP
- ACCESSORIES
- SPECIAL PROJECT



Saint-Gabriel-de-Brandon
 Québec, Canada
 450 835-1777
 info@lanauindustries.com

Specifications and illustrations are
 subject to change without notice.



lanau-industries.com



lanau-industries.com

STANDARD SPECIFICATIONS

SHD THE ULTIMATE TOUGHNESS TEST

- FLOOR AR450 - 1/4" (208 000 PSI)
- SIDES AR450 - 3/16" (208 000 PSI)
- FRONT AR450 - 3/16" (208 000 PSI)
- TAILGATE AR450 - 1/4" (208 000 PSI)

SH THE LIGHTWEIGHT SOLUTION WHEN ROUGHNESS IS REQUIRED

- FLOOR AR450 - 3/16" 208 000 PSI)
- SIDES AR450 - 1/8" (208 000 PSI)
- FRONT AR450 - 1/8" (208 000 PSI)
- TAILGATE AR450 - 3/16" (208 000 PSI)

SM USE MOSTLY BY CONTRACTORS & MUNICIPALITIES FOR SAND AND GRAVEL USE

- FLOOR AR200 - 1/4" (100 000 PSI)
- SIDES 44W - 3/16" (80 000 PSI)
- FRONT 44W - 3/16" (80 000 PSI)
- TAILGATE 44W - 1/4" (80 000 PSI)

SL BEST FOR YOUR GENERAL NEEDS

- FLOOR AR200 - 1/4" (100 000 PSI)
- SIDES 44W - 1/8" (80 000 PSI)
- FRONT 44W - 1/8" (80 000 PSI)
- TAILGATE 44W - 3/16" (80 000 PSI)

STANDARD DIMENSIONS

- LENGTH.....9' TO 32'
- SIDES.....24", 30", 36", 42", 48", 54", 60" TO 66"
- TAILGATE36", 42", 48", 54", 60" TO 66"
- CAB SHIELD.....12", 18", 24", 30", 36" TO 42"
- REAR INSIDE WIDTH.....88 5/8"

OPTIONS

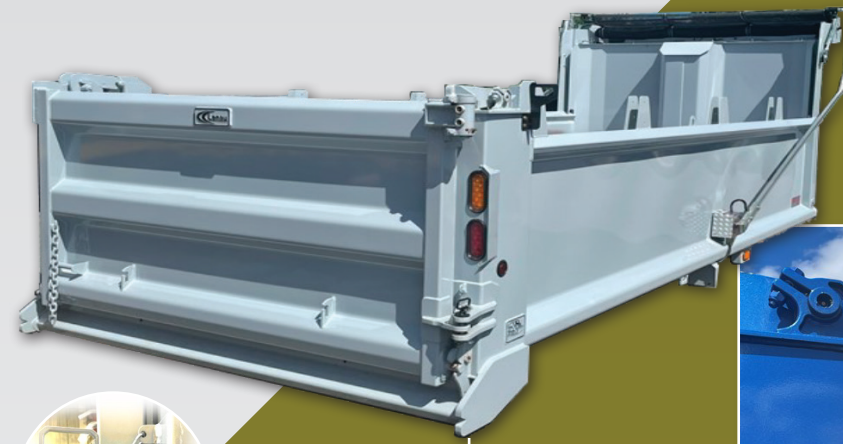

BARN DOOR



AIR TARP LOCK SYSTEM

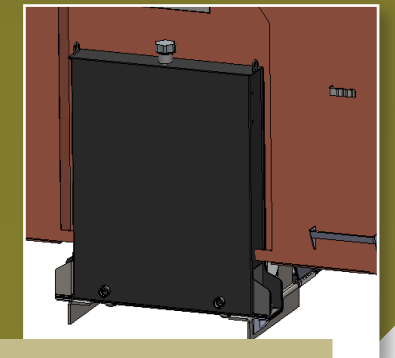

FRONT MOUNTED TANK

OUR PARTS



RUBBER MOUNT ISOLATION SYSTEM



FIFTH WHEEL CLEARANCE



ASPHALT BUMPER



COAL DOOR



REAR LIGHTS HOLES ARE ENGINEERED TO GIVE BETTER VISIBILITY

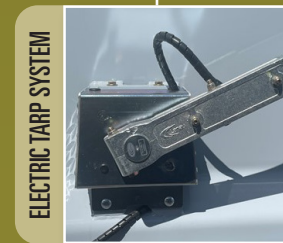

ELECTRIC TARP SYSTEM

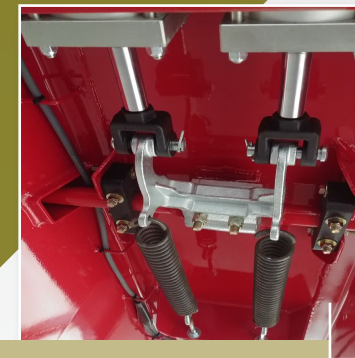

AIR TARP LOCK

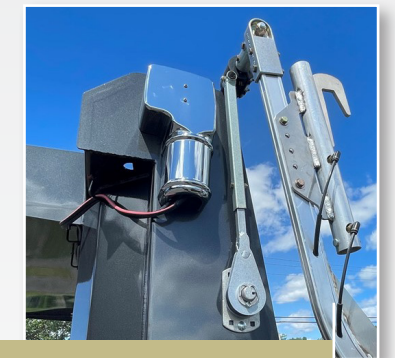

TARP TAMER

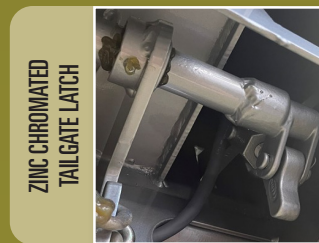

ZINC CHROMATED TAILGATE LATCH



TAILGATE SAFETY LOCK



CYLINDER BLOCK SYSTEM



BOARD HOLDERS

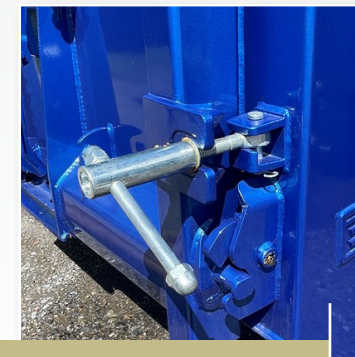

TAILGATE SAFETY LOCK



HIGH LIFT GATE



Top rail is inclined